

Countum Group

SATAM

Metering Solutions



Positive Displacement Meter

ZC 17

The SATAM Positive Displacement Meter (PD meter) is a system with freely-moving blades used to measure petroleum products such as fuels, bio-fuels and refined liquid hydrocarbons and non corrosive chemicals. Its simple design with only two pairs of blades and one moving rotor makes it exceptionally robust and allows the user to make significant savings on maintenance costs.

Flow computers

Measuring systems

Flow meters

Accessories

Sectors of application

Oil depots

For oil product reception and loading stations for tank truck, tank car and ships.

Hydrocarbon transportation

Distribution of fuel oil or fuel by road tanker.

Aircraft refuelling

Aircraft dispensers and aircraft fuelling tankers.

Army

Depot supplies and loading of trucks.

Transport companies

Refuelling of locomotives, trucks and public transport coaches.

Marine applications

Refuelling of ships.

Mining sites

Refuelling of trucks or site machinery.

Key points

Reduced pressure loss

0.3 to 0.5 bar at maximum flow rate.

Low maintenance costs

Simple and robust design with mechanical components interchangeable between the different models.

Stability of measurements

Accuracy of measurement guaranteed over a period of many years without any drift in the calibration curve.

Modular design

Wide range of accessories for performing customized measurement applications.

Robust construction

Flowmeter manifold is separated from measurement chamber to eliminate any possible influence of external mechanical stresses on measurement accuracy.

Few moving parts.

Operating principle

The product enters the measuring chamber following the direction of the arrow. The rotor and blades assembly (1-2) is set in motion by the pressure of the liquid on blades. A certain amount of liquid (3) is held between 2 blades and then directed to the discharge manifold. The volume of liquid measured at each rotation is therefore equal to 4 times the measured quantity (3). The smooth curves the meter pieces provide a steady, non-fluctuating flow resulting in low head loss.

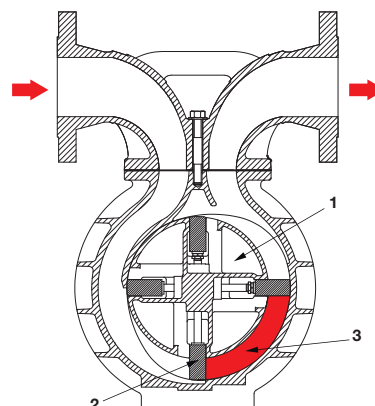

Technical data - PD meter ZC 17

Model	ZC17 12	ZC17 24	ZC17 48	ZC17 80	ZC17 150	ZC17 250	ZC17 330
Application	Custody transfer metering of liquid hydrocarbons						
Max. Flowrate (m ³ /h - L/mn - USGPM)	12-200-53	24-400-105	48-800-210	80-1333-360	150-2500-660	250-4166-1100	330-5500-1453
Min. Flowrate (m ³ /h - L/mn - USGPM)	1.2-20-5.3	2.4-40-10.5	4.8-80-21	8-133-36	15-250-66	25-416-110	33-550-145
Connections DN	2"	2"	2"	3"	4"	6"	8"
Flanges (standard)	Standard Satam			ASA 150 RF			
Flanges (option)	ASA 150 RF			DIN28463TW1		DIN28463TW3	
	Other flanges upon request						
Materials Manifold	Aluminum			Steel or ductile iron or aluminum		Steel or ductile iron	
Casing	Aluminum	Aluminum or Ni resist Iron	Ductile iron or Ni resist iron				
Front and back cover	Carbon steel with protective coating						
Rotor - Blades - Gaskets	Aluminum - Graphite - Viton (option nitrile)						
Operating conditions Max. pressure (operation)	10 bar -150 PSI						
Max. pressure (EC/MID certificate)	8 bar	6 bar (gasoline, kerosene) 8 bar (diesel oil, ethanol)		10 bar			
Max. viscosity	MID : 20mm ² /s (cSt) - Operation : 800 mm ² /s (cSt)						MID : 57mm ² /s
Liquid temperature	-10 °C to +55 °C						
Ambient temperature	Standard : -20 °C to +55 °C - Option : -40 °C to +55 °C Consult us for higher or lower temperatures						
Pressure drop at max flowrate, 3,7 mm ² /s (cSt)	0.45			0.35			
Internal construction Cyclic volume (L - USG)	0,33-0.08	0,40-0.10	0,80-0.21	2,27-0.6	4,54-1.2	6,82-1.8	9.09-2.4
Metrological performances Accuracy	< 0,15 % / Option < 0,1 % For 10 : 1 measuring range						
Repeatability	< 0,02 %						
Installation ATEX certification	Zone 1 - II 2 G						
Custody transfer approval	EC-MID Evaluation Certificate N° LNE-11052 Type Compliance Certificate OIML R117 n°LNE-24351						
Dimensions (mm) and weight	ZC17 12	ZC17 24	ZC17 48	ZC17 80	ZC17 150	ZC17 250	ZC17 330
Distance between flanges (A)	180	180	180	356	432	400	400
Width (B)	290	290	290	356	432	400	400
Depth (C) with mechanical register	220	220	246	365	492	620	746
with pulser	186	186	266	272	399	526	653
Height (D) with mechanical register	368	406	406	502	521	568	625
with pulser	260	260	260	502	521	568	625
Weight (kg) with mechanical register	18	22	26	75	95	155	200
Flanges positions							
Flanges ASA150 with mechanical register	PH1, PH2			PH1, PH2, PV1, PV2, PV3, PV4			
Flanges ASA150 with pulser	PH1, PH2, PV1, PV2, PV3, PV4						
Flanges TW with mechanical register or pulser	-	-	-	PH1, PH2, PV1 to PV10	PH1, PH2, PV1 to PV6	-	-

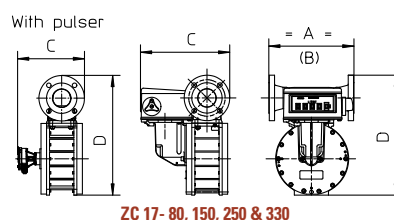
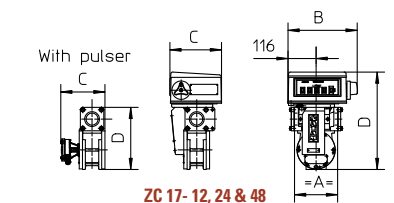
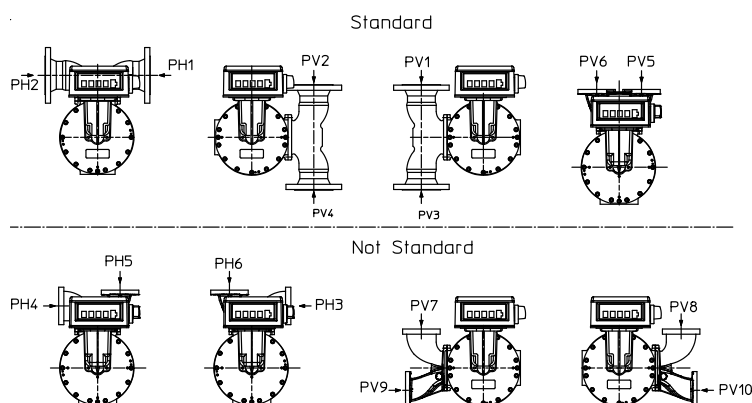

Headquarters and Sales Department

PARIS NORD II
Bat. le Gauvain - 47, allée des Impressionnistes
BP 85012 Villepinte
95931 Roissy CDG Cedex FRANCE
Phone : +33 (0)1 48 63 02 11
Fax : +33 (0)1 49 38 41 01
E-mail : sales@satam.eu

Manufacturing facility

Avenue de Verdun - CS 60129
14700 Falaise FRANCE
Phone : +33 (0)2 31 41 41 41
Fax : +33 (0)2 31 40 75 61



www.satam.eu